

FREEWAY TURNSTILE JETPAN

The «JETPAN» is designed similar to «SPEEDBLADE» turnstile. The only difference of «JETPAN» is high glass panels 1.5m high. Due to this you get effective protection of your site comparable to full-height turnstiles, but at the same time more graceful solution for stylish lobbies of office centers, banks, state facilities. High panels prevent some things being handed over through the turnstile and the «JETPAN» modification with frosted panels visibly separates the protected area from the public eye. Glass panels of the turnstile can be manufactured according to the Customer's choice.

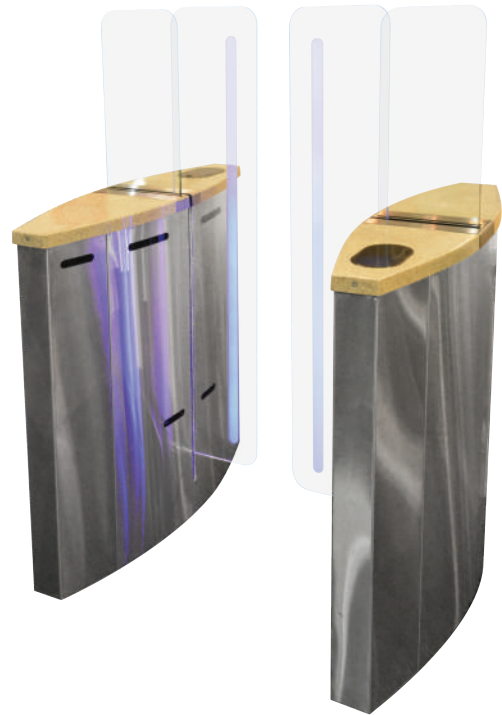

IS THE FASTEST CROWD REGULATOR WITH STYLISH OVAL HOUSING AND GLASS PANELS TO BE LIT IN DIFFERENT COLORS IS MOSTLY LIKED BY MINISTRIES AND RICHEST OFFICE BUILDINGS

Controlled by:

- access control system;
 - manual control
- When power goes OFF both directions are free

Electrical Specifications:

- Voltage:
 - from the AC (100-240)V, 50/60Hz;
 - from s DC source 12 V
- Maximum power consumption 150 Watt per pass;
- Degree of protection according to GOST 14254-96 - IP41

Technical Specifications:

Length	Single pass - 1080 mm Two-pass - 1870 mm
Width	1000 mm
Height	1540 mm
Weight, not more	Single pass - 288 kg Two-pass - 469 kg



www.tiso.global
+380 (44) 291-21-11
e-mail: export@tiso.ua



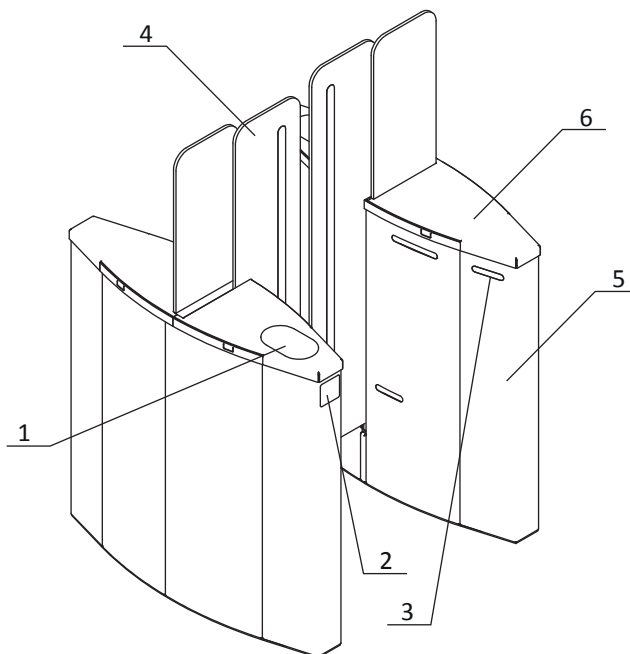
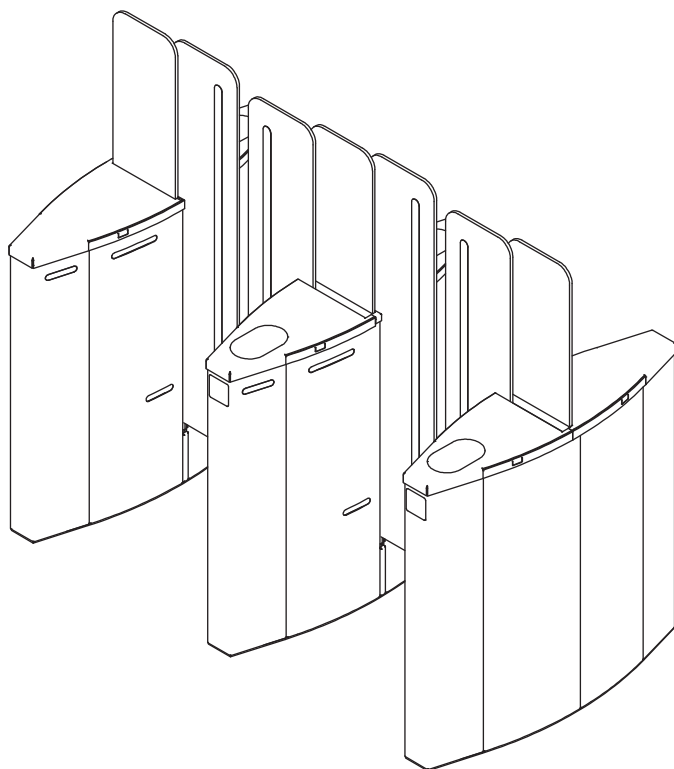
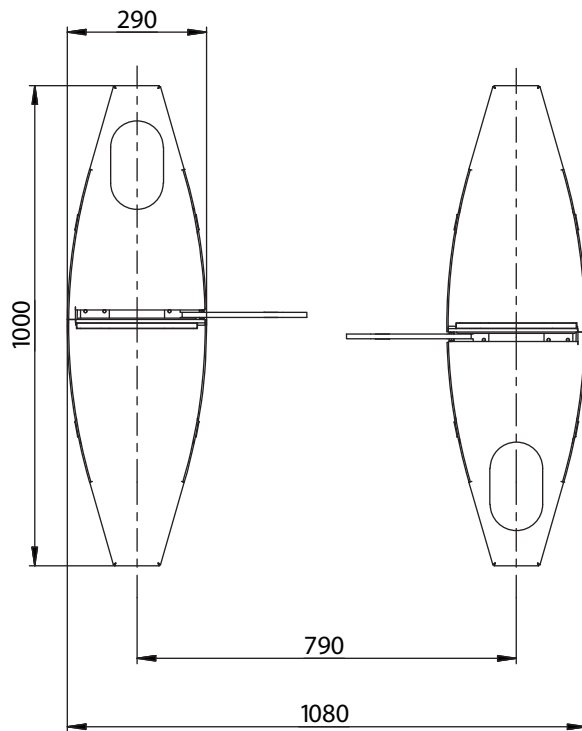
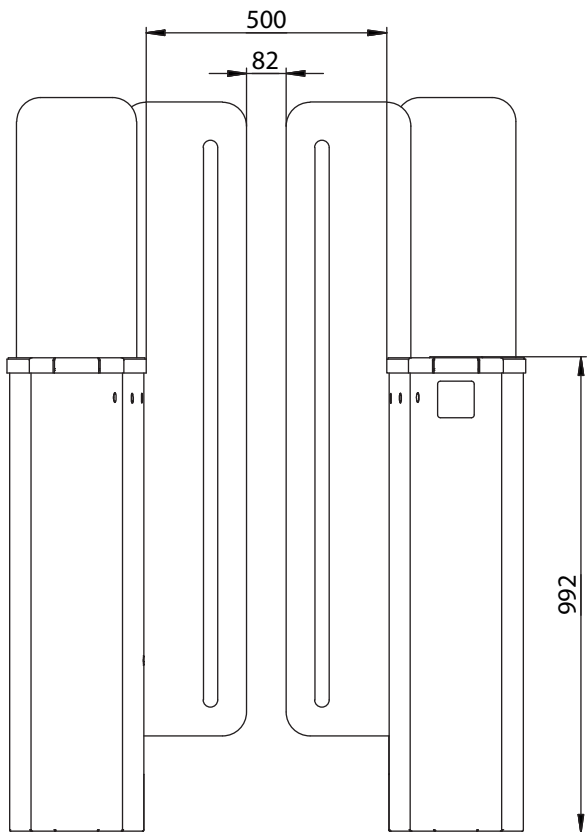

- 1 - card reader and LED display;
- 2 - LED display
- 3 - access sensors;
- 4 - glass leaf;
- 5 - turnstile housing;
- 6 - cover



www.tiso.global
 +380 (44) 291-21-11
 e-mail: export@tiso.ua



JETPAN - 2

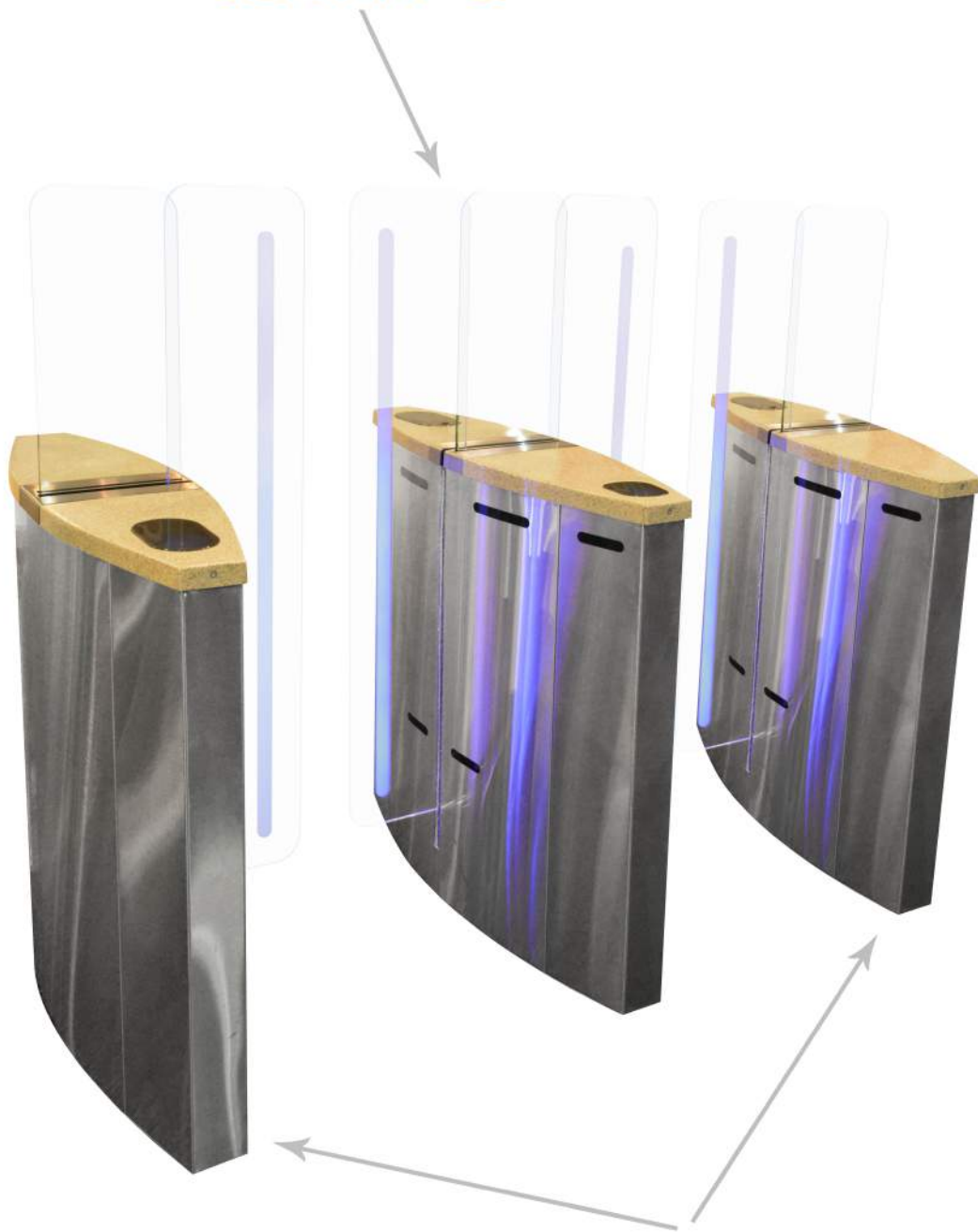

JETPAN - 1



www.tiso.global
+380 (44) 291-21-11
e-mail: export@tiso.ua



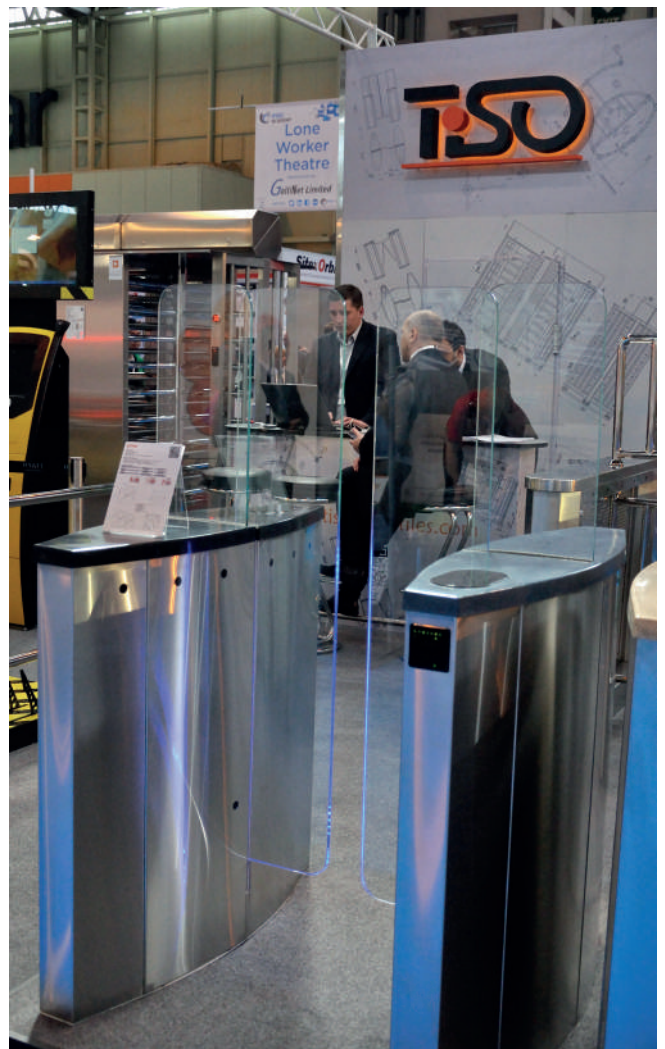

www.tiso.global
+380 (44) 291-21-11
e-mail: export@tiso.ua

